

HELIOS

The perfect partner for your material handling

OKTOMAT®

Octabin and Big Bag emptying system

Type series

OKTOMAT®SOS

OKTOMAT®SOS Classic

OKTOMAT®ECO

OKTOMAT®ECO Classic



2021

www.helios-systems.com

MADE IN GERMANY



The problem

The discharging of octabins and Big Bags through suction pipes is often difficult and not always practical. The conveying is interrupted too often and leads to production disruptions. The film bag is sucked in often or the material does not flow continuously, which is particularly problematic at the end of the discharging process. Often an operator has to guide the suction pipe by hand for a longer period of time in order to discharge a bulk bag.



The solution

OKTOMAT® Emptying stations

The OKTOMAT® uses a vibrating suction head instead of the suction pipe and the automatic bag tightening mechanism pulls the foil inlet or Big Bag upwards. The suction head floats and vibrates in the material and breaks up lumps. The loosened material flows towards the middle and is continuously sucked.

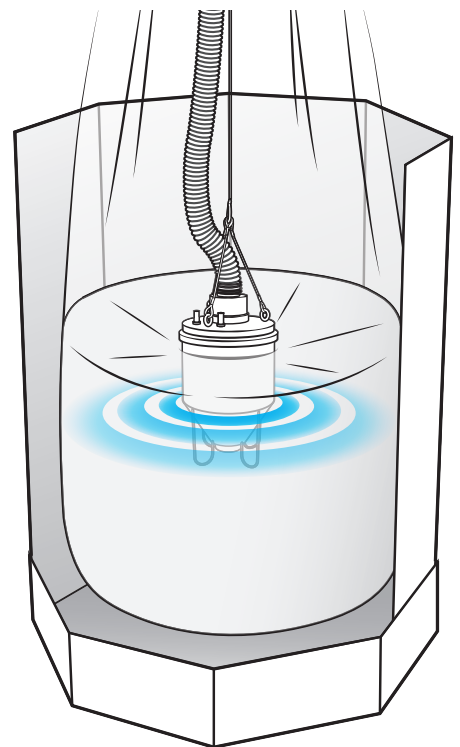

Vibrating suction heads

Functional principle

Automatic bag tightening via pneumatic cylinder

Automatic suction head follow-up with sinking filling level

Video at www.helios-systems.com



1 During the suction process, the flexible bulk bag wall is pulled up and inwards via the automatic bag tightening system.



2 As a result, the bag tightens and the bulk material in the border area flows to the central suction point.



3 At the end of the discharging process, the almost empty bulk bag is automatically lifted up from the bottom, enabling a complete material discharging.

System components

OKTOMAT® SYSTEM



Base frames



Controls



Vibrating suction heads

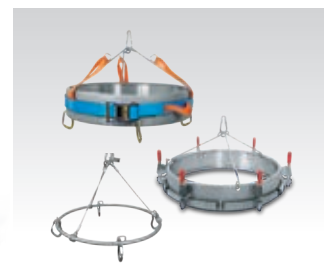

Foil / Big Bag tighteners

The two OKTOMAT® series (SOS and ECO) use components from the OKTOMAT® system in different combinations according to the modular principle. This allows the optimum emptying station to be configured for almost any application.

OKTOMAT® SYSTEM

For all bulk bags with foil inlet or loops

The OKTOMAT® handles easily and effectively the discharging of all common types of Big Bags, octabins, folding boxes, lattice boxes, bulk bags with foil inlet, etc.



Octabin

bulk bags with foil inlets



Big Bag

bulk bags with loops



Lattice boxes

with foil inlets

Just pallet jack will do

Simply use a pallet jack to move the bulk bags, clamp the foil and the suction will follow without supervision and risk of interruption. The bulk bags will be completely emptied.



OKTOMAT® SYSTEM

Bulk material in all variations

OKTOMAT® discharging stations are already suitable for most applications in their basic configuration. However, there are special materials whose characteristic properties must be taken into account when discharging and conveying.

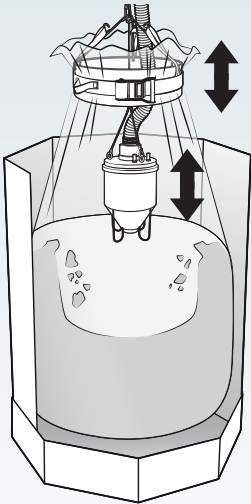

Oscillating suction head and bulk bag tightener

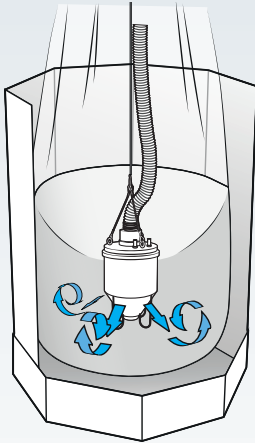

Fluidization

Material-related solutions

For every requirement there are appropriate equipments for the configuration of the optimal discharge station.

Oscillating suction head

Prevents the suction head from going down. Optimum material flow.

Oscillating bulk bag tightener

Brings bridged material and remaining edge areas to collapse.

Special suction head

Different distribution of vibration in the granules, approved materials for the bulk solids, ATEX-compliant, etc.

Fluidization

The material is fluidized additionally, loosening is achieved by compressed air nozzles.

Typical bulk solids that can be discharged easily with OKTOMAT®



activated carbon powder



medical cover caps



cut long glass fibre



mixed herbs



foil punching grid



salt



powder free-flowing



flat foil grinding material



hot-melt adhesives



grinding material from shredder



agglomerat



breadcrumbs

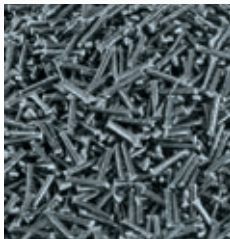

glass fibre sticks



pellets virgin material



rubber granulate

OKTOMAT® Type overview



	SOS	SOS INOX	SOS Classic	
SOS series				
Automatic controlled lifting and lowering of the suction head for optimum suction conditions in the bulk bag Oscillation of the foil / Big Bag tightener as a flow aid for the bulk material in border areas to achieve a max. emptying capacity				
Range	Bag tightening range 1000 mm	Bag tightening range 1000 mm	Bag tightening range 1000/1500 mm	
Type	Pedestal version	Pedestal version	Portal version	
Tension force	Bag tightening force 1500 N	Bag tightening force 1500 N	Bag tightening force 2400 N	
Control	SOS-control	SOS-control	SOS-control	
Configuration	Full equipment	Full equipment	Full equipment	
Functions	<ul style="list-style-type: none"> ■ Automatic complete emptying / automatic bag tightener ■ Oscillating suction head system ■ Oscillating foil / Big Bag tightener system ■ Pipe emptying suction (conveying line) ■ Residual discharge time display ■ Empty signal via LED light and potential-free contact ■ Automatic changeover to the next OKTOMAT® 	<ul style="list-style-type: none"> ■ Automatic complete emptying / automatic bag tightener ■ Oscillating suction head system ■ Oscillating foil / Big Bag tightener system ■ Pipe emptying suction (conveying line) ■ Residual discharge time display ■ Empty signal via LED light and potential-free contact ■ Automatic changeover to the next OKTOMAT® 	<ul style="list-style-type: none"> ■ Automatic complete emptying / automatic bag tightener ■ Oscillating suction head system ■ Oscillating foil / Big Bag tightener system ■ Pipe emptying suction (conveying line) ■ Residual discharge time display ■ Empty signal via LED light and potential-free contact ■ Automatic changeover to the next OKTOMAT® 	
Placement	Especially space-saving in width	Especially space-saving in width	Especially space-saving in depth, installation on hall wall, several stations next to each other	
Operation	Operation sideways	Operation sideways	Operation from the front	
Application	Suitable for almost all tasks	Suitable for almost all tasks, additional corrosion protection	Regrind, punch scrap waste, almost all applications	



SOS Classic INOX	
<p>Autom. lowering the suction head when the filling level decreases via counterweight, foil / Big Bag tightener steplessly adjustable</p>	
Bag tightening range 1400 mm	
Portal version	
Bag tightening force 2500 N	
OKTOBAG®-control	
Fully equipped high-end type	
<ul style="list-style-type: none"> ■ Automatic complete emptying / automatic bag tightener ■ Oscillating suction head system ■ Oscillating foil / Big Bag tightener system ■ Pipe emptying suction (conveying line) ■ Residual discharge time display ■ Empty signal via LED light and potential-free contact ■ Automatic changeover to the next OKTOMAT® ■ Fluidization control ■ Graphic display 	
Especially space-saving in depth, installation on hall wall, several stations next to each other	
Operation sideways or from the front	
Foodstuffs, pharmaceutical industry, corrosion-protected, suitable for high-pressure cleaners	

ECO	ECO Classic
<p>ECO series</p>	
<p>Autom. lowering the suction head when the filling level decreases via counterweight, foil / Big Bag tightener steplessly adjustable</p>	
Bag tightening range 1000 mm	Bag tightening range 1000/1500 mm
Pedestal version	Portal version
Bag tightening force 1500 N	Bag tightening force 2400 N
ECO-control	ECO-control
Basic equipment	Basic equipment, expandable to full equipment
<ul style="list-style-type: none"> ■ Automatic complete emptying / automatic bag tightener ■ Autom. follow-up of the suction head according to filling level via counterweight 	<ul style="list-style-type: none"> ■ Automatic complete emptying / automatic bag tightener ■ Autom. follow-up of the suction head according to filling level via counterweight
Especially space-saving in width	Especially space-saving in depth, installation on hall wall, several stations next to each other
Operation sideways	Operation from the front
Free-flowing bulk materials	Free-flowing bulk materials of high density

OKTOMAT® SOS Series

The all-rounder among the OKTOMAT® discharge stations

For all free-flowing, up to „difficult“ materials

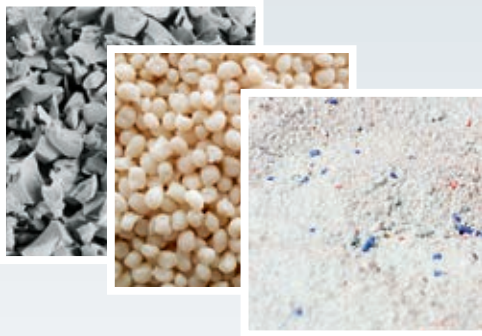

The OKTOMAT® SOS series is able to empty also problematic materials:

- regrind
- free-flowing powders
- bridge-forming granules such as TPE / Soft PVC
- bridge building agglomerates or similar
- food / salts etc.

Suction head oscillating system

The suction head enters vibrating into the material, is pulled up again in a time-controlled manner (the resulting sinkhole in the material fills up), is then lowered back onto the surface and the procedure starts again. The oscillation, stroke, lifting force and sequence of short or long strokes are individually adjustable.

as standard

Foil / Big Bag tightener Oscillating system

In case of very bridging materials, a non-slip wall may occur during the suction process. By repeated lowering and lifting of the foil / Big Bag tightener during suction, the material wall will be loosened, thus enabling the material to flow towards the suction point.

as standard

Maximum functionality

The OKTOMAT® SOS series is already equipped with the most important functions as standard.



OKTOMAT® SOS



OKTOMAT® SOS Classic

Oscillating system for suction head

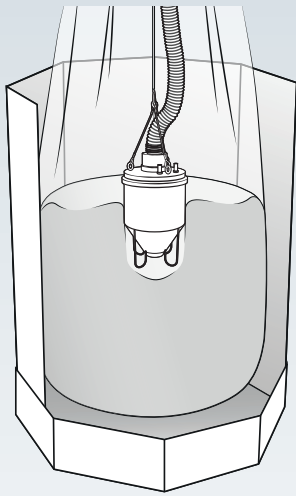

1 During suction, a cavity may result in the suction zone underneath the suction head.

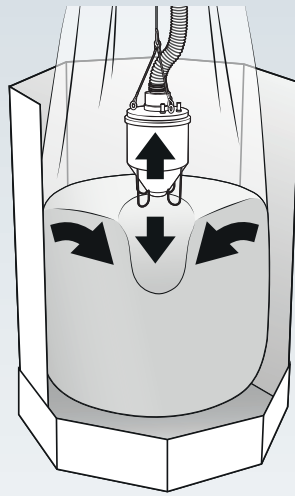

2 The suction head oscillation system raises the suction head. The resulting sinkhole fills up again.

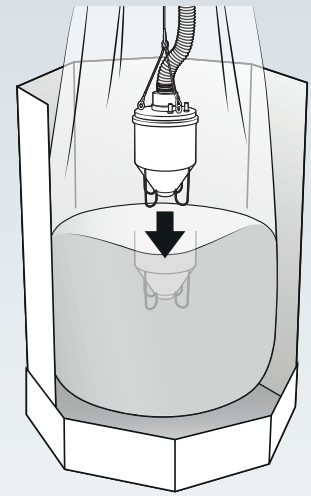

3 The system lowers the suction head back to the surface and makes it sink down time-controlled.

Oscillating system for foil / Big Bag tightener

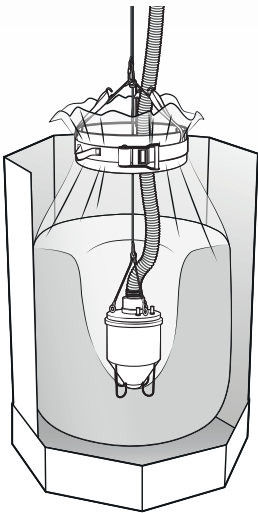

1 The border areas do not slip. A deep sinkhole is formed.

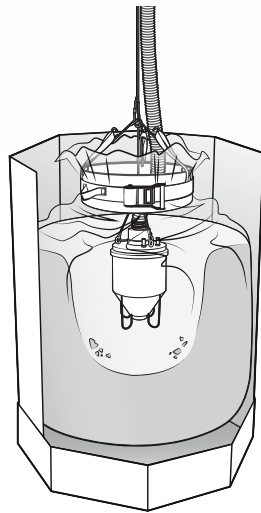

2 The oscillation system lowers the foil / Big Bag tightener towards the bulk material surface and the material under pressure in border area will be released.

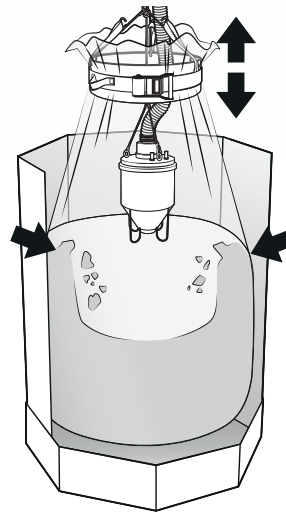

3 The suction head is raised and the oscillating system pulls the foil wall upwards. The constricting container wall presses the material walls into the middle and causes them to collapse.

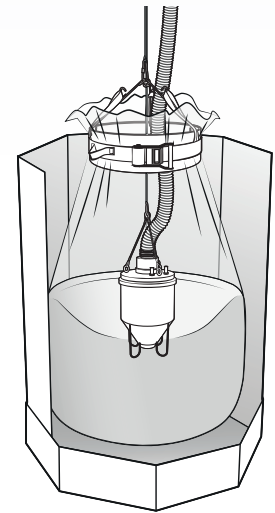

4 The suction head is lowered again and can suck away more material.

Big Bag Bags with loops

Octabin Bags with foil inliner

Particularly space-saving in width

Fully equipped

Suitable for almost all tasks

Suction head oscillating system

Foil / Big Bag tightener oscillating system

- easy to operate
- unmanned operation
- minimal operating costs
- low maintenance
- robust and durable



STANDARD EQUIPMENT

- Pedestal version made of steel, powder-coated
- 8-fold height adjustable
- Foil / Big Bag tightener made of stainless steel, Ø 600 mm for foil inliners and Big Bag
- Automatic complete emptying / automatic bag tightener
- Suction head type S-38 / S-45 / S-50 conveying line 38 / 45 / 50 mm
- Suction head oscillating system
- Foil / Big Bag tightener oscillating system
- Tension force 1500 N
- SOS control
 - Oscillation
 - Empty suction function (conveying line)
 - Residual discharge time display
 - Empty signal via LED light and potential-free contact
 - Automatic changeover to the next OKTOMAT® (control part)

Delivered pre-assembled in transport box.

MATERIALS

Level of difficulty

free-flowing	Materials
poorly flowable	Materials
bridge-forming	Materials

OKTOMAT® SOS is ideally suited for the majority of applications. It handles the emptying of free-flowing to bridge-forming materials. For even more difficult tasks, the discharge station can be extended with options.

Materials	standard	optional
free-flowing	●	
poorly flowable	●	
bridge-forming	●	
difficult	—	●

Placement

Footprint

Due to its pedestal form, the OKTOMAT® SOS is particularly space-saving in its width. An area of approx. 1200 mm x 1900 mm is recommended.

Operation

Containers can be transported on the front, left and right to the OKTOMAT®. The control unit can be easily operated from the side. A remote control is available as an option.

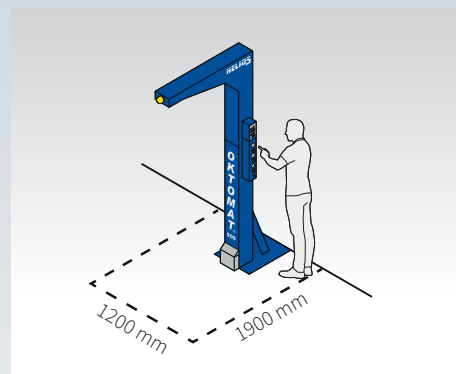

Installation height

Installation height

The OKTOMAT® SOS is 8-fold height-adjustable. The installation height can be selected from 2600 mm - 3650 mm.

Container height

In order to achieve complete emptying, there must be a minimum distance of 1500 mm between the top edge of the container and the top edge of the discharge station.

An increase of 300 mm can be achieved subsequently by means of a base element.

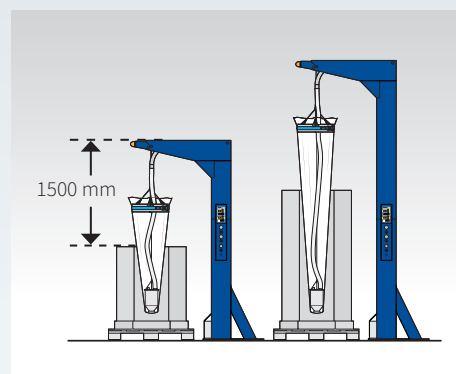

Special versions

- OKTOMAT® SOS INOX
- OKTOMAT® SOS INOX ATEX
- OKTOMAT® SOS partial food version



OPTIONS

- Double station, automatic switching to next OKTOMAT® (pneumatic ball valves)
- Special suction heads SM / XL / S-80 Clean / XL-80 Clean available with conveying line 38 / 45 / 50 / 60 / 65 / 80 mm
- AK-version of suction head S-38, S-50 and SM
- Additional weight for suction head S-38/45/50
- Pneumatic vibrator for suction head
- Fluidization by compressed air via nozzles (suction head SM and XL only)
- Protection cover for containers + foil / Big Bag tightener
- Special size foil / Big Bag tightener Ø 260 / 400 / 500 mm
- Remote control with 5 m cable
- Movable frame on castors, powder-coated
- Movable frame on castors, stainless steel 1.4301 (AISI 304)
- Base element to increase height by 300 mm
- Partial food version for suction head and conveying line
- OKTOBAG® control with intuitive operator guidance and display of all operating states via graphic display

ATEX version



ATEX Zone 22

optionally available in ATEX version

- partial ATEX zone: suction head + conveying line + bulk bag tightener
- complete ATEX version for pedestal, control, suction head, conveying line and bulk bag tightener

Technical specifications

height	2600 - 3650 mm
width / depth	500 mm / 1640 mm
weight / with packaging	170 - 200 kg / 270 - 300 kg
tension force	1500 N
compressed air connection	min. 6 bar. Ø DN 13 mm
electrical connection	~ 230 V AC, 50/60 Hz
	~ 110 V AC, 50/60 Hz

Big Bag

Bags with loops

Octabin

Bags with foil inliner

Particularly space-saving in depth

Increased tension force
for high-density materials

Fully equipped

Suitable for all tasks

Special height available
for extra high containers

Special width available
for extra wide containers

Suction head oscillating system

Foil / Big Bag tightener oscillating system

- easy to operate
- unmanned operation
- minimal operating costs
- low maintenance
- robust and durable



STANDARD EQUIPMENT

- Portal version made of steel, powder-coated
- 7-fold height adjustable
- Foil / Big Bag tightener made of stainless steel, Ø 600 mm for foil inliners and Big Bag
- Automatic complete emptying / automatic bag tightener
- Suction head type S-38 / S-45 / S-50 conveying line 38 / 45 / 50 mm
- Suction head oscillating system
- Foil / Big Bag tightener oscillating system
- Increased tension force 2400 N
- SOS control
 - Oscillation
 - Empty suction function (conveying line)
 - Residual discharge time display
 - Empty signal via LED light and potential-free contact
 - Automatic changeover to the next OKTOMAT® (control part)

Delivered pre-assembled in transport box.

MATERIALS

Level of difficulty

free-flowing	Materials
poorly flowable	Materials
bridge-forming	Materials

OKTOMAT® SOS Classic is ideally suited for the majority of applications. It handles the emptying of free-flowing to bridge-forming materials. For even more difficult tasks, the discharge station can be extended with options.

Materials	standard	optional
free-flowing	●	
poorly flowable	●	
bridge-forming	●	
difficult	—	●

Placement

Footprint

Due to its portal form, the OKTOMAT® SOS Classic is particularly space-saving in depth. An area of approx. 1520 mm x 1160 mm is recommended.

Operation

Containers are transported on the front to the OKTOMAT®. The control unit can be operated directly from the front. A remote control is available as an option.

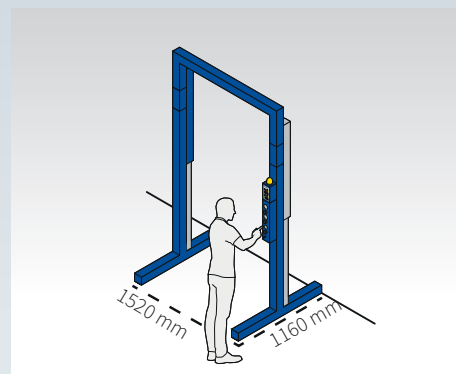

Installation height

Installation height

The OKTOMAT® SOS Classic is 7-fold height-adjustable. The installation height can be selected from 2770 mm - 3670 mm.

Container height

In order to achieve complete emptying, there must be a minimum distance of 1500 mm between the top edge of the container and the top edge of the discharge station.

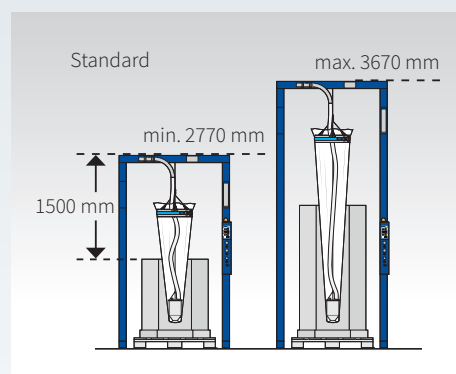

As an option, the maximum construction height can be extended to 4270 mm with an extension (600 mm).

Optionally, the OKTOMAT® can be extended with an extension (300 mm) (for extra wide containers, max. container width 1500 mm).

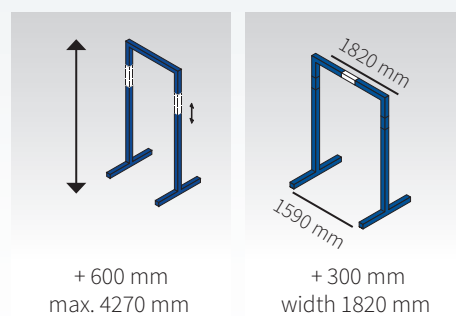

OPTIONS

- Double station, automatic switching to next OKTOMAT® (pneumatic ball valves)
- Special suction heads SM / XL / S-80 Clean / XL-80 Clean available with conveying line 38 / 45 / 50 / 60 / 65 / 80 mm
- AK-version of suction head S-38, S-50 and SM
- Additional weight for suction head S-38/45/50
- Pneumatic vibrator for suction head
- Fluidization by compressed air via nozzles (suction head SM and XL only)
- Protection cover for containers + foil / Big Bag tightener
- Special size foil Big Bag tightener Ø 260 / 400 / 500 mm
- Remote control with 5 m cable
- Special height max. 4270 mm (+ 600 mm)
- Special width 1820 (+ 300 mm)
- Movable frame on castors, powder coated
- Partial food version for suction head and conveying line
- OKTOBAG® control with intuitive operator guidance and display of all operating states via graphic display

ATEX version



ATEX Zone 22

optionally available in ATEX version

- partial ATEX zone:
suction head + conveying line
+ bulk bag tightener

Technical specifications

height	2770 - 3670 mm
width / depth	1520 mm / 1160 mm
weight / with packaging	160 - 220 kg / 260 - 320 kg
tension force	2400 N
compressed air connection	min. 6 bar. Ø DN 13 mm
electrical connection	~ 230 V AC, 50/60 Hz
	~ 110 V AC, 50/60 Hz

Big Bag

Bags with loops

Octabin

Bags with foil inliner

Particularly space-saving in width

Suitable for a wide variety of tasks

Basic configuration

Special heights possible

min. 2500 mm

max. 3900 mm

- easy to operate
- unmanned operation
- minimal operating costs
- low maintenance
- space-saving
- robust and durable

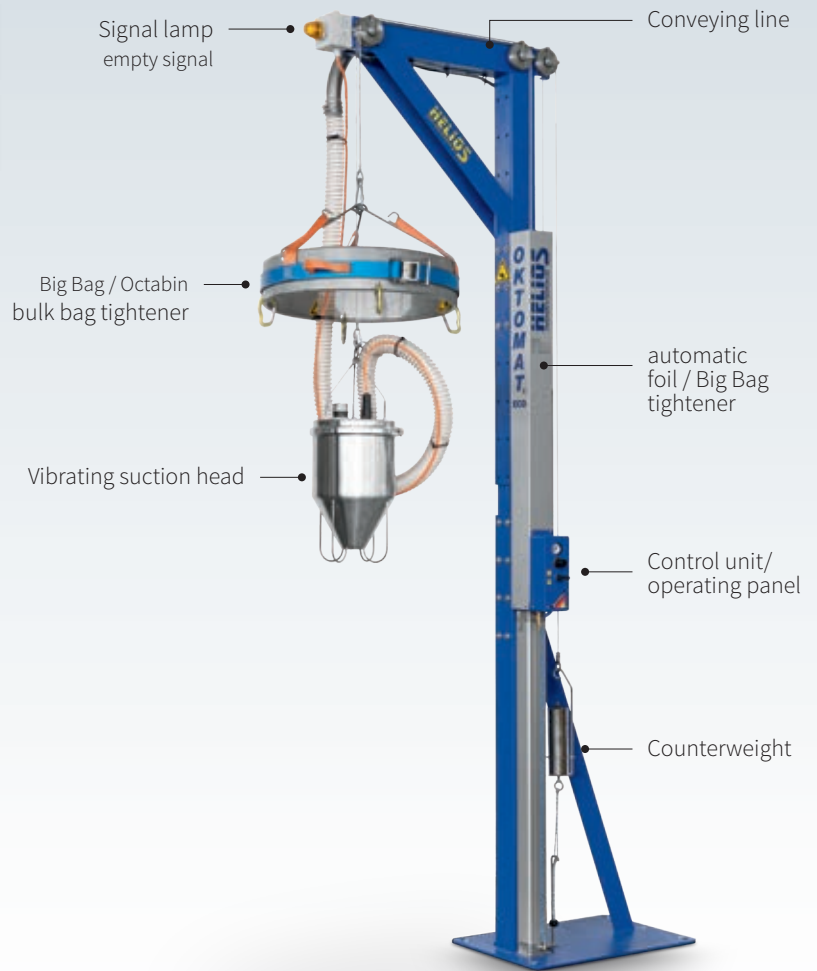

STANDARD EQUIPMENT

- Pedestal version made of steel, powder-coated
- 5-fold height adjustable
- Foil / Big Bag tightener made of stainless steel, Ø 600 mm for foil inliners and Big Bag
- Automatic complete emptying / automatic bag tightener
- Suction head type S-38 / S-45 / S-50 conveying line 38 / 45 / 50 mm
- Autom. follow-up of the suction head according to filling level via adjustable counterweight
- Tension force 1500 N

Delivered pre-assembled in transport box.

MATERIALS

Level of difficulty

free-flowing	Materials
poorly flowable	Materials

OKTOMAT® ECO is ideally suited for the majority of applications. It handles the emptying of free-flowing to poorly flowable materials.

Materials	standard	optional
free-flowing	●	
poorly flowable	●	
bridge-forming	—	●
difficult	—	—

Placement

Footprint

Due to its pedestal form, the OKTOMAT® ECO is particularly space-saving in width. The required area to the front depends on the container type used. An area of approx. 1200 mm x 1900 mm is recommended.

Operation

Containers can be transported on the front, left and right to the OKTOMAT®. The control unit can be easily operated from the side.

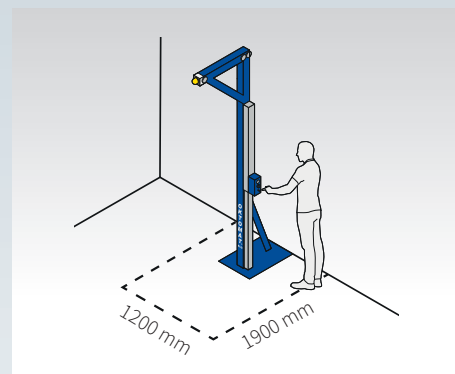

Installation height

Installation height

The OKTOMAT® ECO is 5-fold height-adjustable. The standard installation height can be selected from 3000 mm - 3500 mm. A special height from 3500 mm up to 3900 mm and a space-saving height of only 2500 mm - 3000 mm (4 x 125 mm grid) are available as an option.

Container height

In order to achieve complete emptying, there must be a minimum distance of 1500 mm between the top edge of the container and the top edge of the discharge station.

An increase of 300 mm can be achieved subsequently by means of a base element.

Standard: 3000 - 3500mm

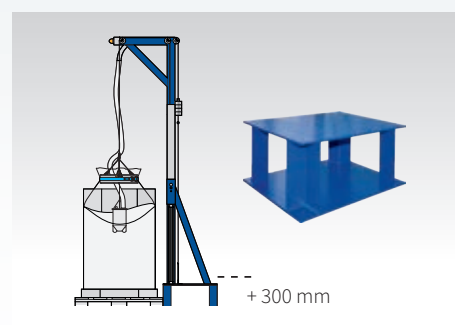
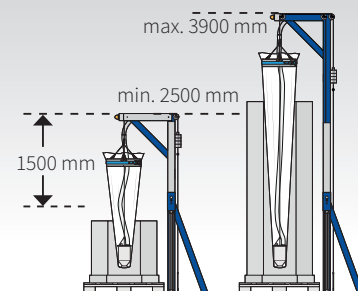

OPTIONS

- ECO-control for empty signal via LED light and potential-free contact, display of residual discharge time
- Double station, automatic switching to next OKTOMAT® (pneumatic ball valves)
- Special suction head XL
available with conveying line 38 / 45 / 50 / 60 / 65 / 80 mm
- AK-version of suction head S-38, S-50 and SM
- Additional weight for suction head S-38/45/50
- Pneumatic vibrator for suction head
- Protection cover for containers + foil / Big Bag tightener
- Special size foil / Big Bag tightener Ø 260 / 400 / 500 mm
- Movable frame on castors, powder-coated
- Partial food version for suction head and conveying line
- Special height: 2500 to 3000 mm
- Special height: 3500 to 3900 mm
- Base element to increase height by 300 mm

ATEX version



ATEX Zone 22

optionally available in ATEX version

- partial ATEX zone:
suction head + conveying line
+ bulk bag tightener

Technical specifications

height	3000 - 3500 mm
width / depth	500 mm / 1540 mm
weight / with packaging	125 - 145 kg / 225 - 245 kg
tension force	1500 N
compressed air connection	min. 6 bar. Ø DN 13 mm
electrical connection	~ 230 V AC, 50/60 Hz
	~ 110 V AC, 50/60 Hz

Big Bag

Bags with loops

Octabin

Bags with foil inliner

Particularly space-saving in depth

Increased tension force
for high-density materials

Basic configuration
expandable up to full SOS equipment

Special assembly height
for extra high containers

Special width
for extra wide containers

- easy to operate
- unmanned operation
- minimal operating costs
- low maintenance
- robust and durable



STANDARD EQUIPMENT

- Portal version made of steel, powder-coated
- 7-fold height-adjustable
- Foil / Big Bag tightener made of stainless steel, Ø 600 mm for foil inliners and Big Bag
- Automatic complete emptying / automatic bag tightener
- Suction head type S-38 / S-45 / S-50 conveying line 38 / 45 / 50 mm
- Autom. follow-up of the suction head according to filling level via adjustable counterweight
- Increased tension force 2400 N

Delivered pre-assembled in transport box.

MATERIALS

Level of difficulty

free-flowing	Materials
poorly flowable	Materials

OKTOMAT® ECO is ideally suited for the majority of applications. It handles the emptying of free-flowing to poorly flowable materials. For even more difficult tasks, the discharge station can be extended with options.

Materials	standard	optional
free-flowing	●	
poorly flowable	●	
bridge-forming	—	●
difficult	—	●

Placement

Footprint

Due to its portal form, the OKTOMAT® ECO Classic is particularly space-saving in depth. An area of approx. 1520 mm x 1160 mm is recommended.

Operation

Containers are transported on the front to the OKTOMAT®. The control unit can be operated directly from the front.

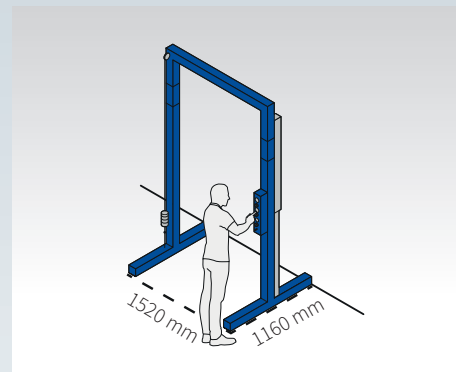

Installation height

Installation height

The OKTOMAT® ECO Classic is 7-fold height-adjustable. The installation height can be selected from 2770 mm - 3670 mm.

Container height

In order to achieve complete emptying, there must be a minimum distance of 1500 mm between the top edge of the container and the top edge of the discharge station.

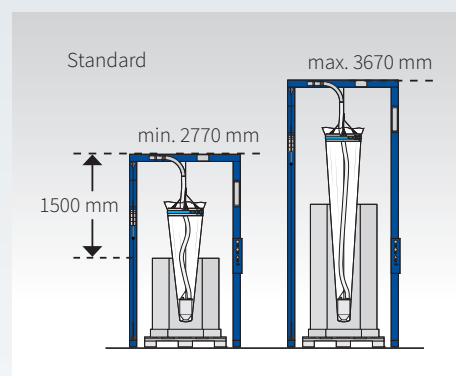

As an option, the maximum construction height can be extended to 4270 mm with an extension (600 mm).

A special width of 1820 mm is available (for particularly wide containers, max. container width 1500 mm).

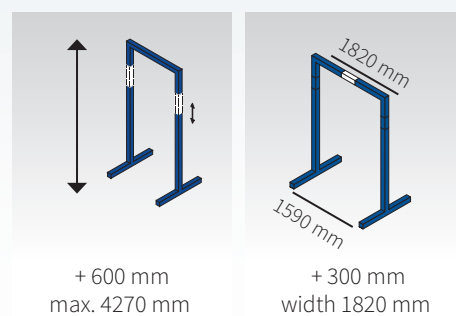

OPTIONS

- ECO-control for empty signal via LED light and potential-free contact, display of residual discharge time
- Double station, automatic switching to next OKTOMAT® (pneumatic ball valves)
- Special suction head XL
available with conveying line 38 / 45 / 50 / 60 / 65 / 80 mm
- AK-version of suction head S-38, S-50 and SM
- Additional weight for suction head S-38/45/50
- Pneumatic vibrator for suction head
- Protection cover for containers + foil / Big Bag tightener
- Special size foil / Big Bag tightener Ø 260 / 400 / 500 mm
- Special height max. 4270 mm (+ 600 mm)
- Special width 1820 mm (+ 300 mm)
- Movable frame on castors, powder-coated
- Partial foodstuff version for suction head and conveying line
- Oscillating system suction head
- Oscillation system foil / Big Bag tightener retrofitable

ATEX version

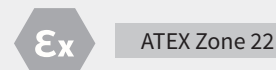

optionally available in ATEX version

- partial ATEX zone:
suction head + conveying line
+ bulk bag tightener
- complete ATEX version for portal,
suction head, conveying line and bulk
bag tightener
(ECO/SOS control not available)

Technical specifications

height	2770 - 3670 mm
width / depth	1520 mm / 1160 mm
weight / with packaging	160 - 220 kg / 260 - 320 kg
tension force	2400 N
compressed air connection	min. 6 bar. Ø DN 13 mm
electrical connection	~ 230 V AC, 50/60 Hz
	~ 110 V AC, 50/60 Hz

Completely made of stainless steel

OKTOMAT® SOS Classic INOX emptying stations are used especially in sensitive production areas with the highest demands.

Oscillating system suction head

Oscillating system bulk bag tightener



- Suitable for high-pressure cleaning
- Resistant to aggressive cleaning agents

STANDARD EQUIPMENT

- Portal version made of stainless steel 1.4301 (AISI 304)
- 10-fold height-adjustable
- Suction head S-80 Clean made of stainless steel 1.4571 (AISI 316) with compressed air vibrators, available with conveying line 38/50/65/80 mm
- Big Bag tightener with 4 stainless steel carabiners
- Automatic complete emptying / automatic bulk bag tightener
- Discharge aids by means of
 - steplessly adjustable vibrators in the suction head
 - oscillation of the suction head
 - oscillation of the bulk bag tightener
- Empty suction function (conveying line)
- Empty signal, potential-free contact
- OKTOBAG® control with intuitive operator guidance and display of all operating states via graphic display

MATERIALS

Level of difficulty

free-flowing	Materials
poorly flowable	Materials
bridge-forming	Materials
difficult	Materials

OKTOMAT® SOS Classic INOX masters all materials from free-flowing to the most difficult materials and is used in particularly sensitive production areas with the highest demands.

Materials	standard	optional
free-flowing	●	
poorly flowable	●	
bridge-forming	●	
difficult	●	

Control

The OKTOBAG® control is an extremely comprehensive discharge control and includes

- Graphic display with intuitive operator guidance
- Display of all operating states
- 5 function keys
- Buttons for automatic operation
- Button for conveyor unit ON/OFF

The entire program sequence can be individually programmed and individual functions can be disabled or enabled. The operating personnel have to take care only of manual or automatic operation.



Status OKTOMAT

actual weight	kg	280
change bag	after	
alarm at	kg	50
immersion time		02
lower bag		2.0

Switch-over Option 2

automatic switch-over ON OFF

Suction head oscillating

Dive	sec	02
short Lift		01
long Lift		00

Lifting ring oscillating

> lowering bag	min	02
lowering time	sec	05
Function Option 9		<input type="checkbox"/> ON <input type="checkbox"/> OFF



S-80 Clean

XL-80 Clean

Big Bag tightener

The ring is suitable for Big Bag with loops. It can be easily converted from low to high containers. Material: stainless steel

Suction head

Vibrating suction head to loosen and suck off the bulk material.
Material: stainless steel 1.4408/1.4571 (AISI 316), PUR conveying hose.

OPTIONS

- Double station, automatic switching to next OKTOMAT® (pneumatic ball valves)
- Weighing of the residual material counting down from 150 kg via strain gauge tension element
- Weighing platform with negative weighing of the entire system
- Foil bag tightener for foil inliners
- Protection cover for bulk bags + foil / Big Bag tightener
- Suction head XL-80 Clean of stainless steel 1.4571 (AISI 316) with pneumatic vibrators

ATEX version



ATEX Zone 22

optionally available in ATEX version

- complete ATEX version including portal and control

Technical specifications

material	1.4301 (AISI 304)
height	2230 - 3730 mm
width / depth	1840 / 1150 mm
weight / with packaging	260 kg / 420 kg
protection type	IP 66 / IP 69 K
compressed air connection	min. 6 bar, max.8 bar, Ø DN 13
electrical connection	~ 230 V AC, 50/60 Hz
	~ 110 V AC, 50/60 Hz

Base frames



Pedestal version ECO



Pedestal version SOS



Portal version ECO/SOS



Portal version INOX

Vibrating suction heads



S-80 Clean XL-80 Clean AK - version

Type	Ø Conveying hose	diameter	Vibrator electric	Vibrator pneumatic	ATEX	CLEAN	AK
S-38	38 mm	295 mm	●	○	○	—	○
S-45	45 mm	295 mm	●	○	○	—	—
S-50	50 mm	295 mm	●	○	○	—	○
SM	38 / 45 / 50 / 60 / 65 / 80 mm	295 mm	—	●	○	—	○
XL	38 / 45 / 50 / 60 / 65 / 80 mm	495 mm	●	○	○	—	—
S-80 C	38 / 50 / 65 / 80 mm	250 mm	—	●	●	●	—
XL-80 C	38 / 50 / 65 / 80 mm	450 mm	—	●	●	●	—

● standard ○ optional — not available

Bulk bag tightener

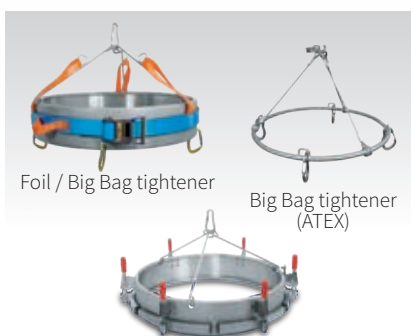

Foil tightener (ATEX)

Special sizes and versions

Type	Use	Diameter	Fixation	
Foil / Big Bag tightener	Big Bag + foil	260 mm	lashing strap + carabiner	○
Foil / Big Bag tightener	Big Bag + foil	400 mm	lashing strap + carabiner	○
Foil / Big Bag tightener	Big Bag + foil	600 mm	lashing strap + carabiner	●
Foil tightener	Foil (ATEX Zone)	600 mm	clamping jaws	○
Big Bag tightener	Big Bag	500 mm	carabiner	○

● standard ○ optional

suitable for all OKTOMAT® types

Controls



Control ECO

Control SOS

Control OKTOBAG®

	SOS	SOS Classic	ECO	ECO Classic
only operating panel	—	—	●	●
Control ECO	—	—	○	○
Control SOS	●	●	—	—
Control OKTOBAG®	○	○	—	—
Control OKTOBAG® ATEX	○	—	—	—

● standard ○ optional — not available

ECO control



Control for residual discharge time or
for residual discharge time and double station

with potential-free contact for empty signal

- adjustable residual discharge time
- basic control for double station

Included as standard in SOS control

suitable for series **OKTOMAT® ECO**
OKTOMAT® ECO Classic

OKTOBAG® control



The OKTOBAG® control is an extremely comprehensive discharge control and includes

- Graphic display with intuitive operator guidance
- Display of all operating states
- 5 function keys
- Buttons for automatic operation
- Button for conveyor unit ON/OFF

The entire program sequence can be individually
programmed and individual functions can be
disabled or enabled.

suitable for series **OKTOMAT® SOS**
OKTOMAT® SOS Classic

Double station



As soon as a signal is received from the ECO / SOS / OKTOBAG® control, the conveying is
switched on to the next full container via pneumatic ball valves.

- Ideal for unmanned shifts

suitable for all OKTOMAT® types

Remote control



Lifting and lowering of suction head and foil / Big Bag tightener, automatic operation

- 5 m cable

suitable for series **OKTOMAT® SOS**
OKTOMAT® SOS Classic

Conveying line emptying

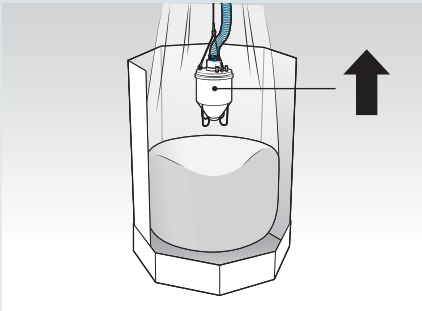

In order to be able to empty the pipeline after each conveying process (e. g. in the case of long rising pipes), the suction head is raised above the bulk material level in the container when a signal is received from a conveyor control system and the pipeline is emptied.

OKTOMAT® SOS

OKTOMAT® SOS Classic

Fluidization

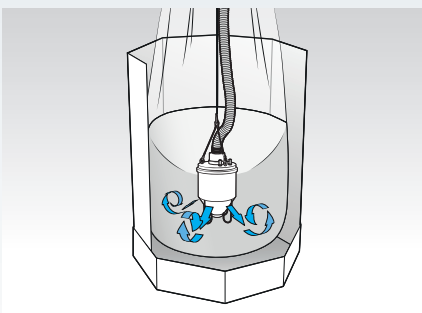

For loosening up dense bulk material, compressed air can be injected to fluidize the material to be sucked off.

available for suction head SM and XL only

separate control with two independent pneumatic circuits

suitable for series OKTOMAT® SOS

OKTOMAT® SOS Classic

Protection cover



Cover for containers + foil / Big Bag tightener

PVC, transparent with zipper

Ø 1200 mm

Ø 1600 mm

suitable for all OKTOMAT® types

Additional weight



The additional weight increases the contact weight of the suction head on the bulk material and thus helps to enter into the bulk material.

- available for suction head S38 / S45 / S50 only
- + 4 kg

suitable for all OKTOMAT® types

Movable frame on castors



Movable frame on 4 castors incl. fixing bolts. Suitable for continuous use.
Height: 155 mm (175 mm when fixed)

Width 1500 mm

Depth 1400 mm

suitable for series OKTOMAT® SOS

OKTOMAT® ECO

Width 1500 mm

Depth 1470 mm

suitable for series OKTOMAT® ECO Classic

OKTOMAT® SOS Classic

Pipe elbows



DN38, DN45 and DN50 (outer diameter)

- Standard pipe elbow (stainless steel 1.4301 (AISI 304))
- Stainless steel pipe elbow (hardened) wear-resistant
- Glass pipe elbow highly wear-resistant

suitable for all OKTOMAT® types

Special height

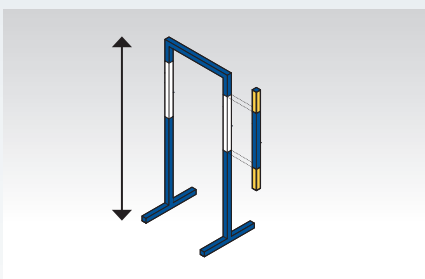

Extension 600 mm for maximum installation height of 4270 mm

suitable for series **OKTOMAT® ECO Classic**
OKTOMAT® SOS Classic

Special width

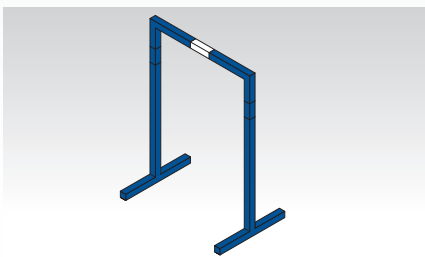

Extension 300 mm for maximum portal width of 1820 mm
for extra wide containers, max. width of container 1500 mm

suitable for series **OKTOMAT® ECO Classic**
OKTOMAT® SOS Classic

Special height

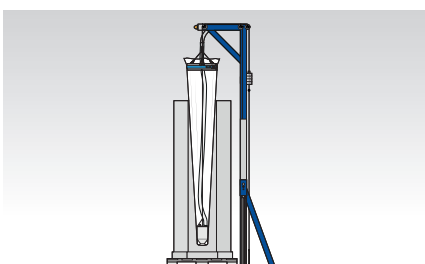

- A: Special height: 3500 - 3900 mm (4 x 100 mm steps)
B: Special height: 2500 - 3000 mm (4 x 125 mm steps).

special version **OKTOMAT® ECO**

Height increasing base element

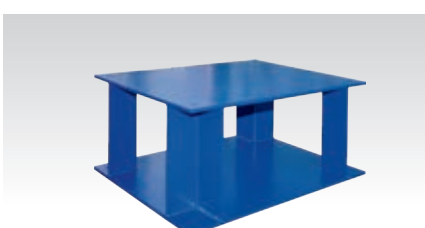

Base element to increase height by 300 mm. Mounting on OKTOMAT® foot section.

- Height: 300 mm
- Weight: 64 kg

suitable for series **OKTOMAT® SOS**
OKTOMAT® ECO

OKTOMAT® SYSTEM

Robust and durable

Thousands of OKTOMAT® systems are in use worldwide. Most of them work in 3-shift operation under the hardest conditions, e.g. in the plastics and chemical industries.

Low maintenance

OKTOMAT® discharging stations are designed for low maintenance and service-friendly. Any necessary spare parts can be changed with just a few steps.

Short payback period

OKTOMAT® discharging stations usually amortize after a few months. The exact amortisation period depends on the savings in terms of man-hours in the respective application case and the costs incurred so far due to production disruptions.

After Sales Service

We do not leave you alone with the HELIOS components, but accompany you through the entire process from the selection up to starting up and training of your employees. That is what we understand by partnership. Our staff will be pleased to advise you on the possible applications of our products and to inform you about our latest technical developments - also for possible retrofits.

- consulting
- starting up
- training
- upgrade
- maintenance/checking up
- spare parts supply within 24h



History of a success story



OKTOMAT® system discharging station wins out worldwide

HELIOS was granted an EP and a US patent for a suction device based on a patent application in 1995, in which a floating suction head is used for discharging bulk bags from above instead of the usual suction pipe. The foil bag is automatically pulled upwards via a tensioning device in order to achieve a complete discharging.

Following this fundamental idea, further procedural and additional features were developed gradually, such as

- Raising the remaining bulk material off the floor
- Clamping of the foil bag by means of a tension belt
- Oscillation of the suction head while discharging
- Fluidization of the bulk material by compressed air via nozzles at the suction head
- Clamping and relieving the bulk bag wall while discharging

which were also **protected by patent**, the “OKTOMAT®” system.

Depending on the task, various frame types have proven to be particularly advantageous in practice.

Since its launch at FAKUMA in 1996, **more than 5000 systems** have been installed worldwide.

OKTOMAT® in practice

OKTOMAT®

- robust and durable
- unmanned operation
- proven in thousands
- easy to operate
- min. operating costs
- suitable for all materials
- short payback period

injection molding blow molding extrusion compression molding

- | | | |
|------------------|-----------------------------|-------------------|
| ■ paper / foil | ■ logistics | ■ automotive |
| ■ PVC processing | ■ paper finishing | ■ plug connectors |
| ■ recycling | ■ chemistry / raw materials | ■ packaging |
| ■ cable | ■ medical technology | ■ foil production |
| ■ optics | ■ food | |
| ■ lighting | ■ raw material handling | |
| ■ WPC | ■ technical parts | |



Hopper loaders



HFE

vacuum hopper loader
of stainless steel / glass
HFE-15K 15 liters
HFE-30K 30 liters



SFG

vacuum hopper loader
of stainless steel
SFG-2 20 liters
SFG-3 20 liters*
SFG-6 60 liters*
*(with enlarged filter)



HCA

vacuum conveyors
of stainless steel
HCA-2 2 liters
HCA-5 5 liters*
*(with enlarged filter)

intermediate
container
5/15 liters

Vacuum stations



HV vacuum station
with 2-step
side channel compressor
2,5 - 7,0 kW



HVK vacuum station
with claw pump
4 - 9 kW

Refilling station

Cantilever arm
+ vacuum conveyor

available for

- OKTOMAT® SOS
- OKTOMAT® SOS Classic
- OKTOMAT® ECO
- OKTOMAT® ECO Classic

local / external assembly

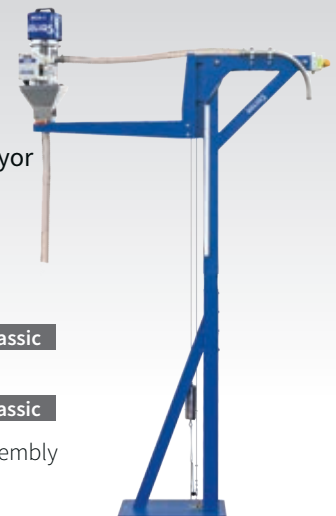

Examples

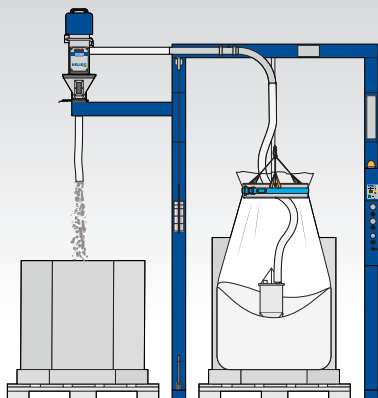

Refilling station

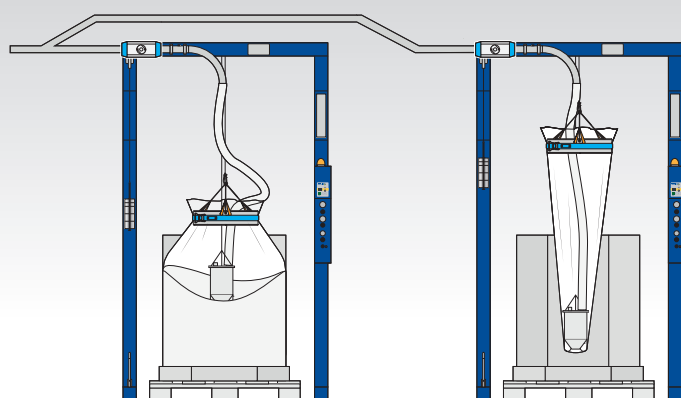

Double station with autom. switchover

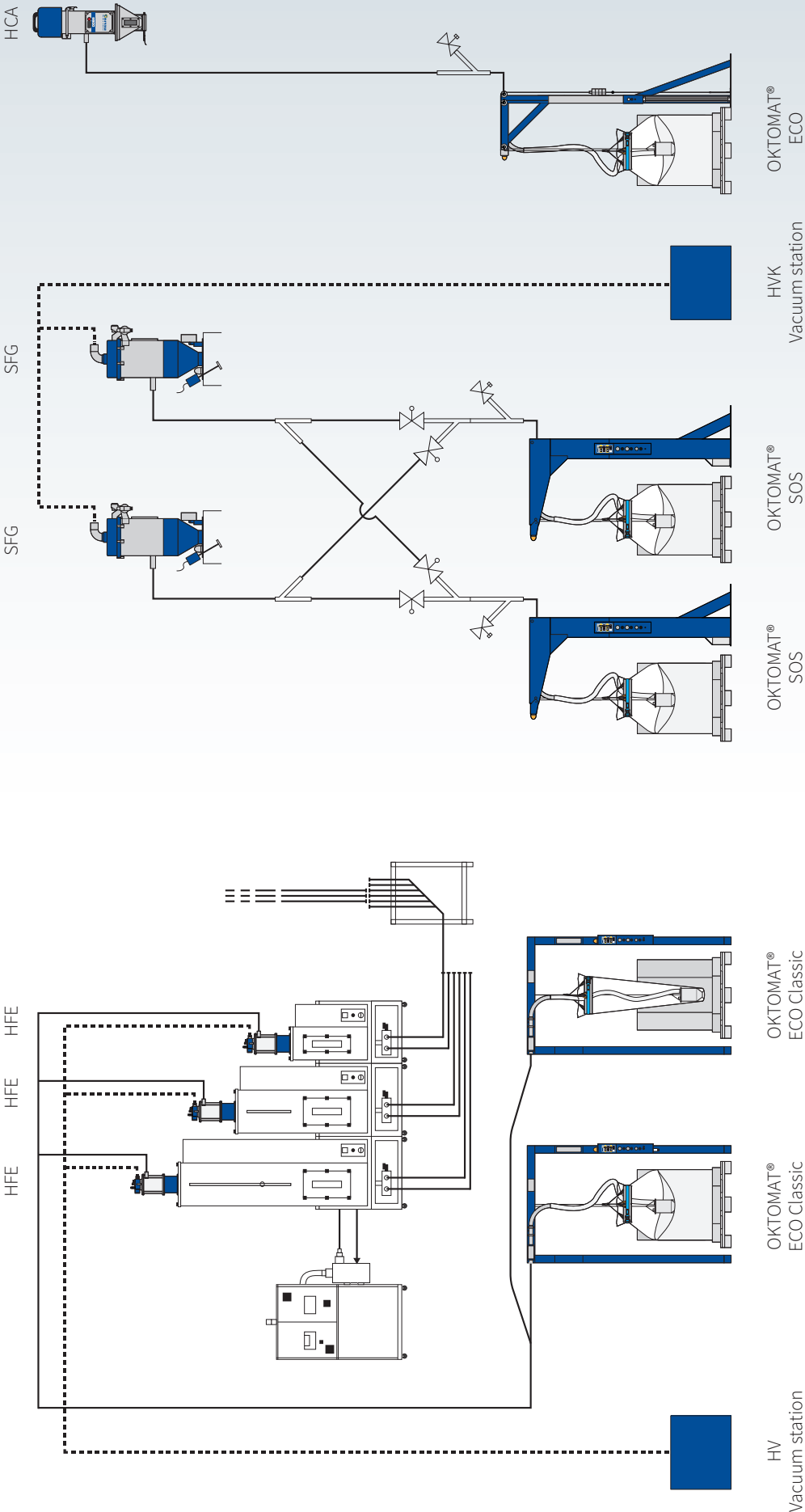



Your perfect partner for material handling



JETBOXX®

Drying system

Dry-air dryers for plastic granulate



OKTOMAT®

Emptying system

Discharging stations for Octabin and Big Bag



HELIO® Clean

Dedusting system

Dedusters for plastic granulate/regrind

HELIOS GmbH

Gerätebau für Kunststofftechnik

Hechtseestraße 8
83022 Rosenheim
GERMANY

Tel +49 (0)8031 35418-0
Fax +49 (0)8031 35418-60

info@helios-systems.com
www.helios-systems.com

